

CESSNA 182

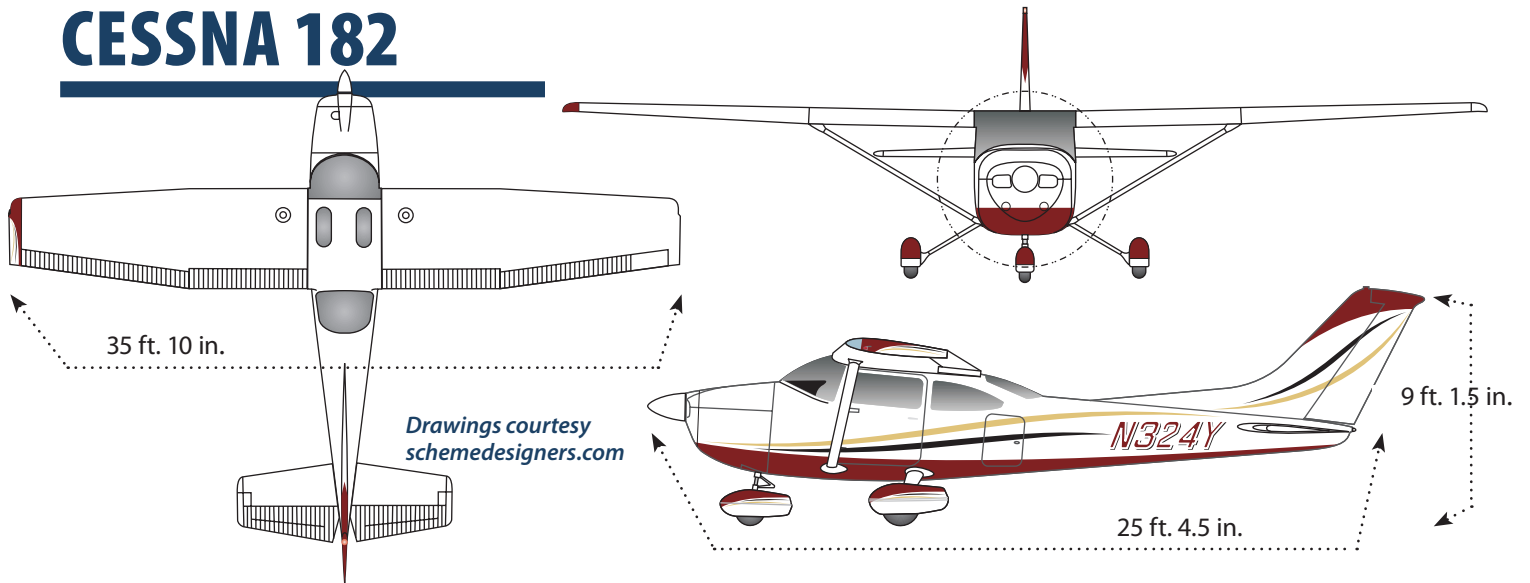

CESSNA 182 SELECT MODEL HISTORY

| MODEL YEAR | ENGINE | TBO | OVERHAUL | FUEL | USEFUL LOAD | CRUISE | TYPICAL RETAIL |
|---------------------|-------------------------|------|----------|-------|-------------|-------------|----------------|
| 1956-1959 182 A,B | CONT 230-HP O-470-L | 1500 | \$25,000 | 55 | 1010 LBS | 117-120 KTS | ±\$31,000 |
| 1960-1965 182 C-H | CONT 230-HP O-470-L | 1500 | \$25,000 | 65-84 | 1090-1190 | 123 KTS | ±\$34,000 |
| 1966-69 182 J-M | CONT 230-HP O-470-R | 1500 | \$25,000 | 65-84 | 1175 | 123 KTS | ±\$41,000 |
| 1970-1971 182 N | CONT 230-HP O-470-R | 1500 | \$25,000 | 65-84 | 1310 | 121 KTS | ±\$44,000 |
| 1972-1974 182 P | CONT 230-HP O-470-R | 1500 | \$25,000 | 61-80 | 1169 | 123 KTS | ±\$46,000 |
| 1975-1976 182 PII | CONT 230-HP O-470-S | 1500 | \$25,000 | 61-80 | 1169 | 125 KTS | ±\$57,000 |
| 1977-1980 182 QII | CONT 230-HP O-470-U | 2000 | \$25,000 | 61-80 | 1169-1390 | 121 KTS | ±\$70,000 |
| 1981-1986 182 RII | CONT 230-HP O-470-U | 2000 | \$25,000 | 92 | 1373 | 124 KTS | ±\$84,000 |
| 1981-1985 T-182 RII | LYC 235-HP O-540-L3C5D | 2000 | \$30,000 | 92 | 1319 | 157 KTS | ±\$85,000 |
| 1997-2000 182 S | LYC 230-HP IO-540AB1A5 | 2000 | \$35,000 | 88 | 1210 | 140 KTS | ±\$140,000 |
| 2001-2005 182 T | LYC 230-HP IO-540AB1A5 | 2000 | \$35,000 | 92 | 1025 | 140 KTS | ±\$160,000 |
| 2001-2005 T182 T | LYC 235-HP TIO-540-AK1A | 2000 | \$40,000 | 92 | 1025 | 159 KTS | ±\$190,000 |
| 2006-2009 182 T | LYC 230-HP IO-540AB1A5 | 2000 | \$35,000 | 92 | 1130 | 145 KTS | ±\$280,000 |
| 2006-2009 T182 T | LYC 235-HP TIO-540-AK1A | 2000 | \$40,000 | 92 | 1025 | 159 KTS | ±\$375,000 |
| 2009-2013 182 T | LYC 230-HP IO-540-AB1A5 | 2000 | \$35,000 | 92 | 1025 | 159 KTS | ±\$360,000 |

RESALE VALUES

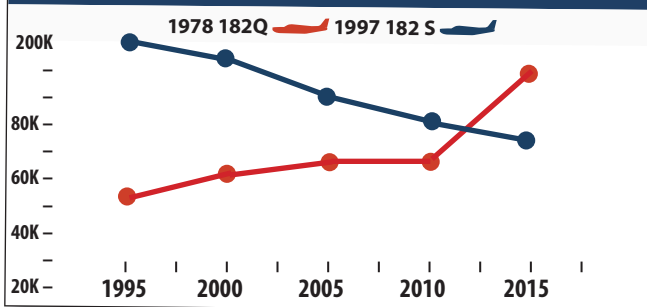

SELECT RECENT ADS (S-MODEL)

- AD 08-26-10 ALTERNATE AIR SELECTOR VALVE
- AD 07-05-10 SEAT BACK LOCK ASSEMBLIES
- AD 04-15-10 BENDIX/KING KAP140 AUTOPILOT
- AD 98-16-04 SPAR CAP ANGLE STIFFENER INSPECTION

PAYLOAD/FULL FUEL

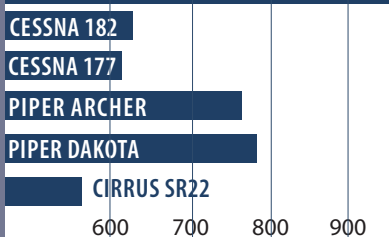

CRUISE SPEEDS

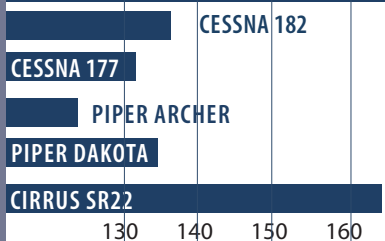

PRICE COMPARISONS

